

TFT Flat Panel Controller with Built-in 3D Video Decoder, Triple ADCs, Dual View and PIP Support

TW8810C

The TW8810 is a highly integrated LCD TFT flat panel controller for Sharp™ dual-view LCD panel primarily targeting front console and rear-seat automotive infotainment applications. The TW8810 integrates a high quality NTSC/PAL/SECAM 3D video decoder and a 2D de-interlacer with low angle compensation. In addition, built-in dual-view mixer enables direct support for Sharp™ dual-view panel.

Applications

- Sharp™ Dual View Display based applications only
- Navigation + DVD + TV
- Back up Camera
- Rear Seat Entertainment
- Car TV
- Portable DVD player
- Portable TV
- In Flight Entertainment

Features

- Supports analog inputs including CVBS, S-Video, YPbPr & RGB signals and digital inputs including 8/16/24 bit RGB/YCbCr. Interlaced and progressive ITU 656 inputs are supported
- Supports Sharp™ dual-view digital panel with resolutions up to WVGA
- Integrated low cost 16-bit SDRAM memory controller supporting up to 8MB SDRAM external memory
- Supports PIP/MPIP
- Built-in dual-view mixer block to support Sharp™ dual-view digital panel
- Built-in dual window bit-mapped (4/8-bits) OSD
- Supports external 18-bit OSD with alpha blending control
- PIP Overlay
- Embedded Image Enhancement
- Programmable CTI, hue, brightness, saturation, contrast & sharpness control
- Black/White Stretch
- Programmable favorite color enhancement- up to three colors (Skin, Grass & Sky)
- Programmable Gamma Correction tables

3D Analog Video Decoder

- NTSC (M, 4.34) and PAL (B, D, G, H, I, M, N, N combination), PAL (60), SECAM with automatic format detection
- Three 10-bit ADCs and analog clamping circuit.
- Fully programmable static gain or automatic gain control for the Y or CVBS channel
- Programmable white peak control for the Y or CVBS channel
- Software selectable analog inputs allows any of the following combinations:
- Up to 4 composite video
- Up to 2 S-Video
- Up to 1 YPbPr

Features (Continued)

Analog RGB Inputs

- Triple high speed 8-bit ADCs with clamping and programmable gain amplifier.
- Up to two independent RGB / YPbPr channels with corresponding SOG
- Built-in line locked PLL with sync separator
- Allows high resolution components inputs like DTV 480i, 480p, 576i, 576p, 720p & 1080i
- Supports PC inputs up to SXGA

8/16/24-bit YCbCr Inputs

- Allows connection with alternative Video and PC Graphics inputs
- Support both 656 and 601 video formats
- Allows connection to HDMI receiver

TFT Panel Support

- Supports Sharp™ dual-view panel up to WVGA
- Supports 3, 4, 6 or 8 bits per pixel up to 16.8 million colors with built-in dithering engine
- Support single channel TTL panel
- Built-in programmable timing controller

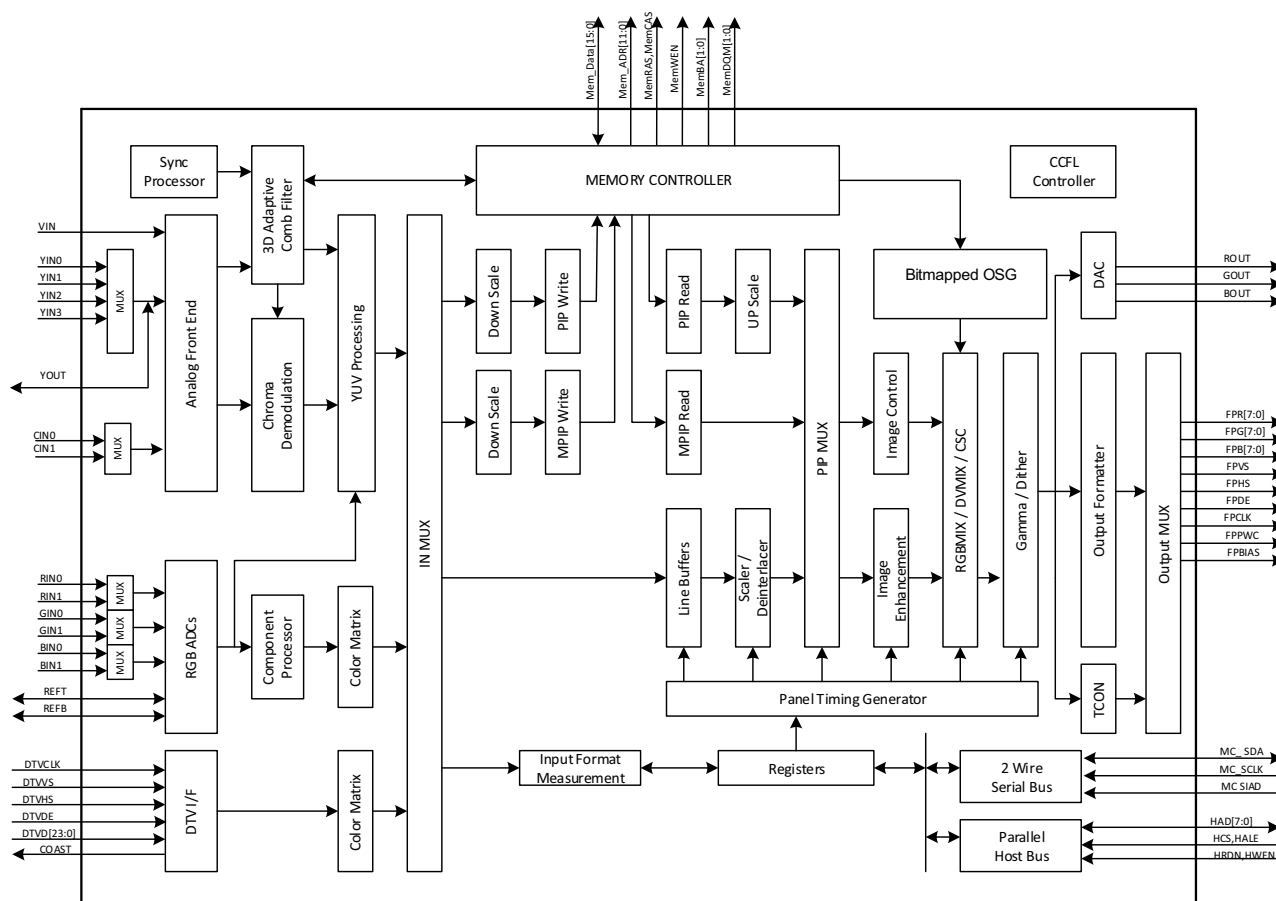

FIGURE 1. TW8810 FLAT PANEL TV/MONITOR CONTROLLER FUNCTIONAL BLOCK DIAGRAM

For additional products, see www.intersil.com/en/products.html

Intersil products are manufactured, assembled and tested utilizing ISO9001 quality systems as noted in the quality certifications found at www.intersil.com/en/support/qualandreliability.html

Intersil products are sold by description only. Intersil Corporation reserves the right to make changes in circuit design, software and/or specifications at any time without notice. Accordingly, the reader is cautioned to verify that data sheets are current before placing orders. Information furnished by Intersil is believed to be accurate and reliable. However, no responsibility is assumed by Intersil or its subsidiaries for its use; nor for any infringements of patents or other rights of third parties which may result from its use. No license is granted by implication or otherwise under any patent or patent rights of Intersil or its subsidiaries.

For information regarding Intersil Corporation and its products, see www.intersil.com